

Prześwietlenie  $\varnothing 9.2$   
Minimum through hole  $\varnothing 9.2$

Szczegół główki 5:1  
Detail of neck finish 5:1

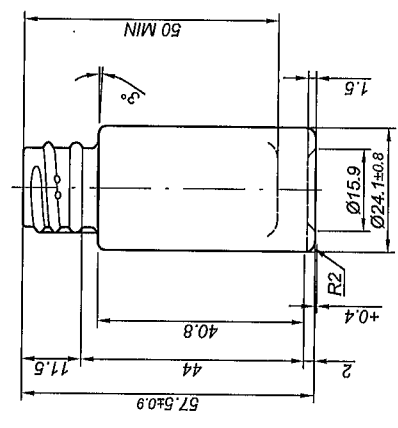
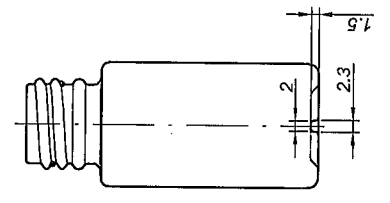
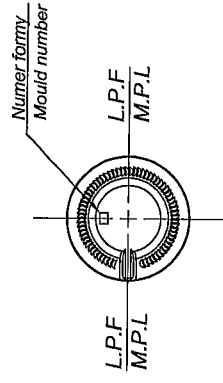
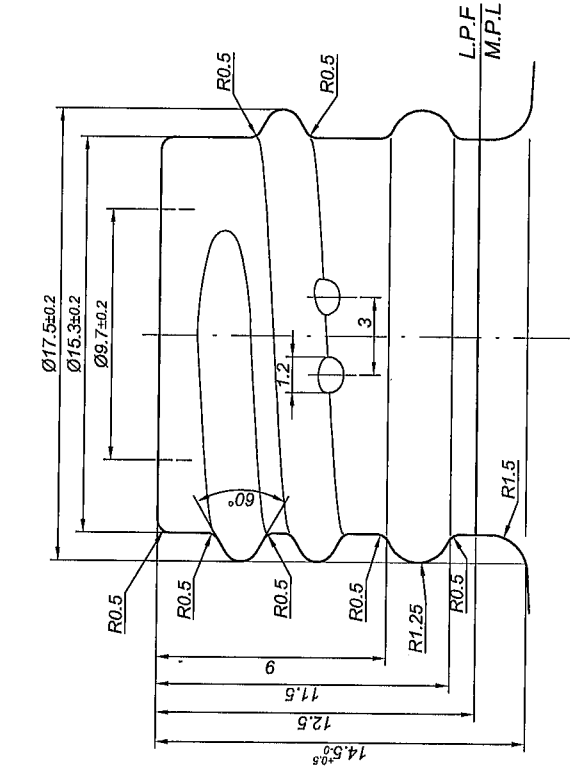

L. P. F. - Linia podziałowa formy  
M.P.L. - Mould partition line

Zmiana / Draw	04-06-2024	Dodanie wymiaru głębokości wewnętrznej	
Wersja / Version	01	Opis / Description	
Skala / Scale	1:1	Forma / Mould	Projektant / Designed by
	A3	Shim size	M. Bylinka
			Rysownik / Drawn by
			M. Bylinka
			Sprawdził / Checked by
			G. Rutkowski
		Klient / Customer	Oskar Karla GmbH
		Nazwa / Article	OSKAR 11
		Główna / Finish	GWINT DEDYKOWANY
		Nr rys. klienta / Customer No.	7385 000
		Nr projektu SAP / SAP-project No.	D.004316
		Typ projektu / Commercial	CPG/06
		Załącz. rys. nr / Drawing No.	
		Pojemność całkowita / Brutto capacity	11±0.9ml
		Ciepła / Weight	~27g
		Wymiary w milimetrach / Dimensions in millimeters	
		Tolerancje wymiarów / Dimensional tolerances	
		Wykończenie powierzchni / Surface finish	
		Uwagi / Remarks	
		Wyd. 05 23.06.2023	